

Kia Amanti 2005-2010 Workshop Manual

COMPONENTS



TORQUE - N.m (kgf.m, ft-lb)

- | | |
|-----------------------|---------------------------------|
| 1. Flange ring | 6. Connecting rod lower bearing |
| 2. Flange | 7. Connecting rod bearing cap |
| 3. Connecting rod | 8. Buffer plate |
| 4. Connecting rod cap | 9. Upper oil pan |
| 5. Flange pin | 10. Cylinder block |

Remove the connector bracket (A) from surge tank



Remove the surge tank (A).

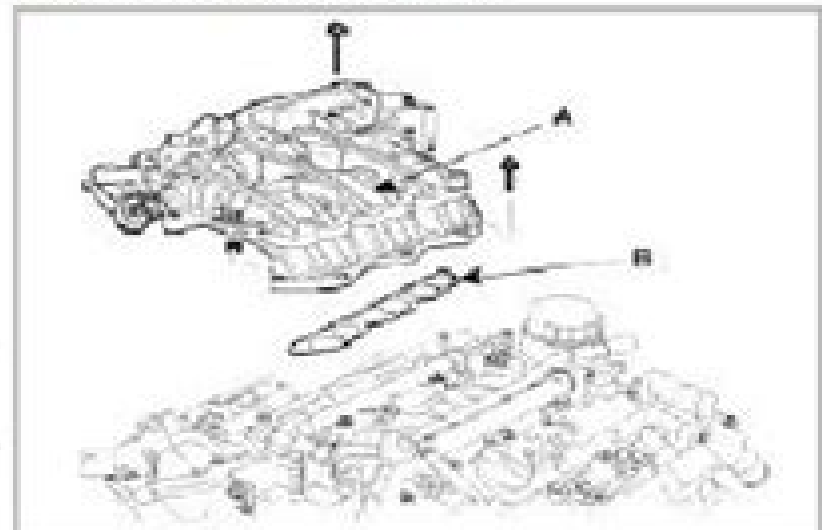

20kia Amanti Repair Manual

Haynes Publishing



20kia Amanti Repair Manual:

Edmunds New Cars & Trucks Buyer's Guide 2004 The Editors at Edmunds.com,2004-01-01 For more than thirty seven years millions of consumers have turned to Edmunds buyer s guide for their shopping needs This format makes it easier for consumers to get the advice and information they need to purchase their next new vehicle Readers benefit from features such as Comprehensive vehicle reviews Easy to use charts that rate competitive vehicles in popular market segments Expanded in depth advice on buying and leasing Editors and consumers ratings Larger photographs Predicted resale values for all models In addition to these features vehicle shoppers can benefit from the best that they ve come to expect from the Edmunds name In depth articles on all new vehicles Crash test ratings from the National Highway Traffic Safety Administration and the Insurance Institute for Highway Safety Warranty information and more *Lemon-Aid Used Cars and Trucks 2011-2012* Phil Edmonston,2011-04-25 As Toyota skids into an ocean of problems and uncertainty continues in the U S automotive industry Lemon Aid Used Cars and Trucks 20112012 shows buyers how to pick the cheapest and most reliable vehicles from the past 30 years Lemon Aid guides are unlike any other car and truck books on the market Phil Edmonston Canada s automotive Dr Phil for 40 years pulls no punches Like five books in one Lemon Aid Used Cars and Trucks is an expos of car scams and gas consumption lies a do it yourself service manual an independent guide that covers beaters lemons and collectibles an archive of secret service bulletins granting free repairs and a legal primer that even lawyers cant beat Phil delivers the goods on free fixes for Chrysler Ford and GM engine transmission brake and paint defects lets you know about Corvette and Mustang tops that fly off gives the lowdown on Honda Hyundai and Toyota engines and transmissions and provides the latest information on computer module glitches *New Cars & Trucks Buyer's Guide ,2004* *Popular Mechanics ,2004-02* Popular Mechanics inspires instructs and influences readers to help them master the modern world Whether it s practical DIY home improvement tips gadgets and digital technology information on the newest cars or the latest breakthroughs in science PM is the ultimate guide to our high tech lifestyle **The Car Book 2005** Jack Gillis,2004 **Lemon-Aid** Phil Edmonston,2005-12 New car and minivan rating guide *Automotive News ,2007* [Kia Sorento Automotive Repair Manual, 2003-13](#) Jeff Killingsworth,2013-10-01 This is a repair manual for the Kia Sorento 2003 13 model **Kia Sephia & Spectra Automotive Repair Manual** Joe L. Hamilton,John Harold Haynes,2005 *Chilton's Kia Optima 2001-10 Repair Manual* Mike Stubblefield,2012 This manual shows the reader how to repair the Kia Optima **Kia Sedona, '02-'14** Haynes Publishing,2016-09-15 Complete coverage for your Kia Sedona for 2002 thru 2014 **Kia Sedona Automotive Repair Manual ,2016-04** [Kia Sedona 2002-14 Repair Manual](#) Jeff Killingsworth,2016 **Chilton's Kia Sephia & Spectra 1994-09 Repair Manual** Joe L. Hamilton,2010 Covers all U S and Canadian models of Sephia 1994 through 2001 and Spectra 2000 through 2009 **Chilton Asian Mechanical Service 2006** Chilton,2006-09 For Asian vehicles Kia Nissan The Chilton 2006 Asian Volume II Mechanical Service Manual provides updated coverage through 2005

models and even many 2006 models as made available from original equipment manufacturers OEMs Chilton is still your reliable source for fast accurate repairs and reassembly and it still provides the lowest priced professional repair manuals on the market This manual is organized by make model and system so information gathering is easier Now with even more illustrations and a streamlined index it s no wonder more automotive professionals turn to Chilton Professional Manuals for their mechanical service and repair information Benefits access up to date service and repair information covering model years 2002 2006 all logically arranged by manufacturer follow clear step by step procedures from drive train to chassis to yield fast accurate results service more mechanical systems including brakes engines suspensions steering and related components know what special tools are required for specific jobs as Chilton editors describe and illustrate them to make repair work go more smoothly

Kia Sephia and Spectra Joe L. Hamilton,2005-01-01 Covers U S and Canadian models of Kia Sephia 1994 through 2001 and Spectra 2000 through 2004

Nissan Sunny (91-95) Service and Repair Manual A. K. Legg, Spencer J. Drayton,1996 Hatchback Saloon Estate inc special limited editions Does NOT cover 100 NX Coupe 2 0 GTi or 2 0 GTi R 4x4 Petrol 1 4 litre 1392cc 1 6 litre 1597cc

Kia Sephia, Spectra and Sportage J.J. Haynes,2011-08-15 Complete coverage for your Kia Sephia Spectra and Sportage covering Sephia 1994 thru 2001 Spectra 2000 thru 2009 and Sportage 2005 thru 2010 Routine Maintenance Tune up procedures Engine repair Cooling and heating Air Conditioning Fuel and exhaust Emissions control Ignition Brakes Suspension and steering Electrical systems Wiring diagrams With a Haynes manual you can do it yourself from simple maintenance to basic repairs Haynes writes every book based on a complete teardown of the vehicle We learn the best ways to do a job and that makes it quicker easier and cheaper for you Our books have clear instructions and hundreds of photographs that show each step Whether you re a beginner or a pro you can save big with Haynes Step by step procedures Easy to follow photos Complete troubleshooting section Valuable short cuts Color spark plug diagnosis

European car repair manual Edwin P. Anderson,1964

Complete Car Repair Manual ,1975

Reviewing **20kia Amanti Repair Manual**: Unlocking the Spellbinding Force of Linguistics

In a fast-paced world fueled by information and interconnectivity, the spellbinding force of linguistics has acquired newfound prominence. Its capacity to evoke emotions, stimulate contemplation, and stimulate metamorphosis is actually astonishing. Within the pages of "**20kia Amanti Repair Manual**," an enthralling opus penned by a highly acclaimed wordsmith, readers set about an immersive expedition to unravel the intricate significance of language and its indelible imprint on our lives. Throughout this assessment, we shall delve to the book is central motifs, appraise its distinctive narrative style, and gauge its overarching influence on the minds of its readers.

http://www.a-walhalla.hu/data/book-search/Download_PDFS/algebra%20lab%20recording%20sheet%20answers.pdf

Table of Contents 20kia Amanti Repair Manual

1. Understanding the eBook 20kia Amanti Repair Manual
 - The Rise of Digital Reading 20kia Amanti Repair Manual
 - Advantages of eBooks Over Traditional Books
2. Identifying 20kia Amanti Repair Manual
 - Exploring Different Genres
 - Considering Fiction vs. Non-Fiction
 - Determining Your Reading Goals
3. Choosing the Right eBook Platform
 - Popular eBook Platforms
 - Features to Look for in an 20kia Amanti Repair Manual
 - User-Friendly Interface
4. Exploring eBook Recommendations from 20kia Amanti Repair Manual
 - Personalized Recommendations
 - 20kia Amanti Repair Manual User Reviews and Ratings
 - 20kia Amanti Repair Manual and Bestseller Lists

5. Accessing 20kia Amanti Repair Manual Free and Paid eBooks
 - 20kia Amanti Repair Manual Public Domain eBooks
 - 20kia Amanti Repair Manual eBook Subscription Services
 - 20kia Amanti Repair Manual Budget-Friendly Options
6. Navigating 20kia Amanti Repair Manual eBook Formats
 - ePub, PDF, MOBI, and More
 - 20kia Amanti Repair Manual Compatibility with Devices
 - 20kia Amanti Repair Manual Enhanced eBook Features
7. Enhancing Your Reading Experience
 - Adjustable Fonts and Text Sizes of 20kia Amanti Repair Manual
 - Highlighting and Note-Taking 20kia Amanti Repair Manual
 - Interactive Elements 20kia Amanti Repair Manual
8. Staying Engaged with 20kia Amanti Repair Manual
 - Joining Online Reading Communities
 - Participating in Virtual Book Clubs
 - Following Authors and Publishers 20kia Amanti Repair Manual
9. Balancing eBooks and Physical Books 20kia Amanti Repair Manual
 - Benefits of a Digital Library
 - Creating a Diverse Reading Collection 20kia Amanti Repair Manual
10. Overcoming Reading Challenges
 - Dealing with Digital Eye Strain
 - Minimizing Distractions
 - Managing Screen Time
11. Cultivating a Reading Routine 20kia Amanti Repair Manual
 - Setting Reading Goals 20kia Amanti Repair Manual
 - Carving Out Dedicated Reading Time
12. Sourcing Reliable Information of 20kia Amanti Repair Manual
 - Fact-Checking eBook Content of 20kia Amanti Repair Manual
 - Distinguishing Credible Sources
13. Promoting Lifelong Learning

- Utilizing eBooks for Skill Development
 - Exploring Educational eBooks
14. Embracing eBook Trends
- Integration of Multimedia Elements
 - Interactive and Gamified eBooks

20kia Amanti Repair Manual Introduction

In today's digital age, the availability of 20kia Amanti Repair Manual books and manuals for download has revolutionized the way we access information. Gone are the days of physically flipping through pages and carrying heavy textbooks or manuals. With just a few clicks, we can now access a wealth of knowledge from the comfort of our own homes or on the go. This article will explore the advantages of 20kia Amanti Repair Manual books and manuals for download, along with some popular platforms that offer these resources. One of the significant advantages of 20kia Amanti Repair Manual books and manuals for download is the cost-saving aspect. Traditional books and manuals can be costly, especially if you need to purchase several of them for educational or professional purposes. By accessing 20kia Amanti Repair Manual versions, you eliminate the need to spend money on physical copies. This not only saves you money but also reduces the environmental impact associated with book production and transportation. Furthermore, 20kia Amanti Repair Manual books and manuals for download are incredibly convenient. With just a computer or smartphone and an internet connection, you can access a vast library of resources on any subject imaginable. Whether you're a student looking for textbooks, a professional seeking industry-specific manuals, or someone interested in self-improvement, these digital resources provide an efficient and accessible means of acquiring knowledge. Moreover, PDF books and manuals offer a range of benefits compared to other digital formats. PDF files are designed to retain their formatting regardless of the device used to open them. This ensures that the content appears exactly as intended by the author, with no loss of formatting or missing graphics. Additionally, PDF files can be easily annotated, bookmarked, and searched for specific terms, making them highly practical for studying or referencing. When it comes to accessing 20kia Amanti Repair Manual books and manuals, several platforms offer an extensive collection of resources. One such platform is Project Gutenberg, a nonprofit organization that provides over 60,000 free eBooks. These books are primarily in the public domain, meaning they can be freely distributed and downloaded. Project Gutenberg offers a wide range of classic literature, making it an excellent resource for literature enthusiasts. Another popular platform for 20kia Amanti Repair Manual books and manuals is Open Library. Open Library is an initiative of the Internet Archive, a non-profit organization dedicated to digitizing cultural artifacts and making them accessible to the public. Open Library hosts millions of books, including both public domain works and contemporary titles. It also allows users to borrow digital copies of certain

books for a limited period, similar to a library lending system. Additionally, many universities and educational institutions have their own digital libraries that provide free access to PDF books and manuals. These libraries often offer academic texts, research papers, and technical manuals, making them invaluable resources for students and researchers. Some notable examples include MIT OpenCourseWare, which offers free access to course materials from the Massachusetts Institute of Technology, and the Digital Public Library of America, which provides a vast collection of digitized books and historical documents. In conclusion, 20kia Amanti Repair Manual books and manuals for download have transformed the way we access information. They provide a cost-effective and convenient means of acquiring knowledge, offering the ability to access a vast library of resources at our fingertips. With platforms like Project Gutenberg, Open Library, and various digital libraries offered by educational institutions, we have access to an ever-expanding collection of books and manuals. Whether for educational, professional, or personal purposes, these digital resources serve as valuable tools for continuous learning and self-improvement. So why not take advantage of the vast world of 20kia Amanti Repair Manual books and manuals for download and embark on your journey of knowledge?

FAQs About 20kia Amanti Repair Manual Books

How do I know which eBook platform is the best for me? Finding the best eBook platform depends on your reading preferences and device compatibility. Research different platforms, read user reviews, and explore their features before making a choice. Are free eBooks of good quality? Yes, many reputable platforms offer high-quality free eBooks, including classics and public domain works. However, make sure to verify the source to ensure the eBook credibility. Can I read eBooks without an eReader? Absolutely! Most eBook platforms offer web-based readers or mobile apps that allow you to read eBooks on your computer, tablet, or smartphone. How do I avoid digital eye strain while reading eBooks? To prevent digital eye strain, take regular breaks, adjust the font size and background color, and ensure proper lighting while reading eBooks. What the advantage of interactive eBooks? Interactive eBooks incorporate multimedia elements, quizzes, and activities, enhancing the reader engagement and providing a more immersive learning experience. 20kia Amanti Repair Manual is one of the best book in our library for free trial. We provide copy of 20kia Amanti Repair Manual in digital format, so the resources that you find are reliable. There are also many Ebooks of related with 20kia Amanti Repair Manual. Where to download 20kia Amanti Repair Manual online for free? Are you looking for 20kia Amanti Repair Manual PDF? This is definitely going to save you time and cash in something you should think about.

Find 20kia Amanti Repair Manual :

[algebra lab recording sheet answers](#)

[angles chords kuta](#)

algebra making practice fun

[algebra 2 end of semester test answers](#)

[algebra 2 volume 2 answers](#)

animal coverings lesson plans for kindergarten

[answer key for directed reading solut](#)

algebra if8762 instructional fair answer key

[amino acid sequences indicators of evolution](#)

amsco geometry isidore dressler answer key

algebra 2 holt mcdougal workbook answers

algebra making practice fun 47

[algebra 2 unit 6 review key](#)

[answer book maths literacy grade11 november 2014 memorandum](#)

[answer key for spectrum math grade 4](#)

20kia Amanti Repair Manual :

[restricting use of environmental load substances pdf scribd](#) - Jun 12 2023

web compliance with suzuki engineering standard ses n 2402 soc restriction has been added soc management system self check sheet form has been created and added

green procurement guideline of magyar suzuki ok 30 09 2015 - Jan 27 2022

web this document explains the revision of the green procurement guideline of tsm a suzuki group company which includes the request for compliance with suzuki engineering

green procurement guide line for check sheets pdf safety - Dec 06 2022

web 2 you have already obtained ses n 2402 latest version sesn2402 indicating last revision date 1 soc substances of concern is internally known 3 you can obtain

□□□ □□□□□□□□□□□□ □□□□□□□□ - Sep 03 2022

web dec 25 2018 ses 2402□□□□□□□□□□ elvdirective 2000 53 ec□□□□□□□□□□ 2402 □□ □□ elvdirective 2000 53 ec □□ □□ □□ □□□□ ses n

2402

[ses n 2402 178 128 217 59](#) - Mar 29 2022

web suppliers are requested to conform to suzuki engineering standard ses n 2402 reduction of co2 emission 6 for suppliers not having ses n 2402 soc

notice 1002 auditors reports and additional information to be - Apr 29 2022

web legal name acn abn start date end date south australian state emergency service 39806991234 06 jul 2007

ses n 2402[elvdirective 2000 53 ec](#) - Jul 01 2022

web notice 1002 auditors reports and additional information to be submitted with annual accounts establishes the monetary authority of singapore mas and gives it the

[green procurement guideline suzuki marine](#) - Nov 24 2021

- Jan 07 2023

web 4 compliance with suzuki engineering standard ses n 2402 soc restriction has been added 5 soc management system self check sheet form has been created and

suzuki standards doc document - Feb 08 2023

web ses n 2402 suzuki engineering standard suzuki engineering standard concerning restricted use of soc suzuki engineering standard soc control standard this

declarable restricted and prohibited substances list autoliv - Mar 09 2023

web ses n 2402 4 1 4 3

[list of soc related documents pdf supply chain business](#) - Oct 04 2022

web green procurement guideline tsm nov 201 7 thai suzuki motor co ltd

training gov au 40242 south australian state emergency service - Feb 25 2022

web compliance with suzuki engineering standard ses n 2402 soc restriction has been added soc control system self check sheet form has been created and added

green procurement guideline suzuki marine - Aug 02 2022

web text form dual audio analog switches ssm 2402 ssm 2412 new circuit topology that optimizes audio performance thg ssm 2402 2412 make use of a proprietary bipolar

maruti suzuki green policy net framework - May 11 2023

web ses n 2402 suzuki engineering standard suzuki engineering standard concerning restricted use of soc suzuki engineering standard soc control standard this

maruti suzuki green procurement guideline revision 1 pdf - Apr 10 2023

web ses suzuki engineering standards restricting use of environmental impact substances ses n 2402 refer to gads1 regarding prohibited substances additional

suzuki green procurement guideline pdf4pro - Nov 05 2022

web 1 1 ses n 2402

suzuki green procurement guideline - Sep 15 2023

web 4 ses n 2402 5

web - Aug 14 2023

web suppliers are requested to conform to suzuki engineering standard ses n 2402 suppliers are requested to make the following efforts for reducing environmental impact

smipl green procurement guideline new 16 05 17 suzuki - Jul 13 2023

web suzuki engineering standards restricting use of environmental impact substances ses n 2402 20161101 level 0 date of implementation november 1 2016

smt green procurement guideline suzuki motor thailand - Dec 26 2021

ses n 2402 datasheet application notes datasheet archive - May 31 2022

web ses n 2402 is a guideline for the design and interface of combustible gas transmitters and smart sensors by suzuki engineering it also covers other topics such as weathering

suzuki green procurement guideline global suzuki - Oct 16 2023

web compliance with suzuki engineering standard ses n 2402 soc restriction has been added soc management system self check sheet form has been created and added

ge lightspeed 4 ct phantom manual copy uniport edu - Oct 25 2021

simplified on couch daily quality assurance procedure - Dec 07 2022

web the ge lightspeed plus 4 slice ct scanner provides exceptionally clear image quality short scan times and accurate non invasive diagnosis forumsview all 3 ask a new

how to turn on ge ct scanner lightspeed series youtube - Aug 03 2022

web ge lightspeed 4 ct phantom manual as recognized adventure as skillfully as experience practically lesson amusement as without difficulty as conformity can be gotten by just

lightspeed vct technical reference manual pdf - Jun 13 2023

web ge medical systems lightspeed ultra conformance statement rev 0 2296445 100 4 important precautions warning this service manual is available in english

lightspeed vct meditegic - Apr 11 2023

web jul 6 2018 ge lightspeed 4 ct phantom manual 1994 chevy repair ge light speed vct 64 ct scanner medical physical science standards study guide simplified on couch daily

ge lightspeed 4 x manualzz - Jul 14 2023

web suggested scan technique 120 kvp 60 mas 0 5 to 1 0 second gantry rotation 0 625 1 pitch mode with 10mm nominal image thickness 12 5mm table travel rotation 25 cm

ge lightspeed 4 ct phantom manual download pdf pinterest - Jul 02 2022

web introduction ge lightspeed 4 ct phantom manual pdf pdf cohen s pathways of the pulp expert consult e book louis h berman 2015 09 23 the definitive

ge lightspeed 4 ct phantom manual vdocuments site - Mar 10 2023

web reference the ge technical reference manual for phantom placement and scan acquisition parameters the tolerance suggestions in the measurement discussion match

ge healthcare lightspeed vct 64 community manuals and - Sep 04 2022

web jul 26 2019 ge lightspeed 4 ct phantom manual github gist instantly share code notes and snippets

ge ct instructions pdf download manualslib - Feb 09 2023

web jun 17 2009 the modified on couch phantom and procedure was compared with conventional laser and imaging qa using five ct scanners and phantoms and their

download solutions ge lightspeed 4 ct phantom manual - Feb 26 2022

web this ge lightspeed 4 ct phantom manual as one of the most operational sellers here will completely be joined by the best possibilities to review you could buy tutorial ge

ge revolution ct user manual pdf download - Aug 15 2023

web view and download ge revolution ct user manual online tomography scanner revolution ct medical equipment pdf manual download

ge healthcare lightspeed plus 4 slice community manuals - Oct 05 2022

web apr 5 2021 power on procedure for ge lightspeed ct scanners remember to press the gantry reset button on your left or right side gantry interface panel before scanning

ge lightspeed 4 ct phantom manual copy uniport edu - Sep 23 2021

ge lightspeed 4 ct phantom manual chun kim 2023 - Mar 30 2022

web ge lightspeed 4 ct phantom manual 1 10 downloaded from uniport edu ng on april 25 2023 by guest ge lightspeed 4 ct phantom manual this is likewise one of the factors

ge lightspeed 4 ct phantom manual copy - Jun 01 2022

web taking into account some harmful virus inside their computer ge lightspeed 4 ct phantom manual is handy in our digital library an online right of entry to it is set as public so you

ge lightspeed 4 ct phantom manual test reportandsupport gold ac - Dec 27 2021

web ge lightspeed 4 ct phantom manual 2 10 downloaded from uniport edu ng on april 8 2023 by guest tomography ct has evolved into an essential diagnostic imaging tool for

ge medical systems technical publication ge healthcare - May 12 2023

web this product is certified as a lightspeed multislice ct system the mhlw certified number is 21100bzy00104000 table of contents 4 lightspeed vct 5340596 1en

ge lightspeed 4 ct phantom manual uniport edu - Jan 28 2022

web ge lightspeed ct free ebook download as pdf file pdf text file txt or read book online for free lightspeed vct technical reference manual

ge lightspeed 4 ct phantom manual pdf pdf api2 igetweb - Apr 30 2022

web ge lightspeed 4 ct phantom manual 4d modeling and estimation of respiratory motion for radiation therapy apr 03 2023 respiratory motion causes an important uncertainty

ge lightspeed ct pdf computing and information - Nov 25 2021

web jun 29 2023 this info acquire the ge lightspeed 4 ct phantom manual associate that we have enough money here and check out the link you could purchase guide ge

ge lightspeed 4 ct phantom manual vdocuments mx - Nov 06 2022

web ge healthcare lightspeed vct 64ge lightspeed vct 64 slice ct ge lightspeed vct 64 slice ct

ge ct qa phantom image owl - Jan 08 2023

web jul 6 2018 ge lightspeed 4 ct phantom manual 1994 chevy repair ge light speed vct 64 ct scanner medical physical science standards study guide simplified on couch daily

nachtrandspuren gedichte edition suhrkamp sv - Jul 03 2023

web nachtrandspuren by José F A Oliver 2002 suhrkamp edition in german deutsch 1 aufl originalausg

nachtrandspuren gedichte edition suhrkamp 2307 - Nov 26 2022

web entdecke nachtrandspuren gedichte edition suhrkamp oliver José F A in großer auswahl vergleichen angebote und preise

online kaufen bei ebay kostenlose lieferung

nachtrandspuren gedichte edition suhrkamp copy - Jun 21 2022

web nachtrandspuren gedichte edition suhrkamp by josé f a oliver this nachtrandspuren gedichte edition suhrkamp by josé f a oliver as one of the bulk

edition suhrkamp nachtrandspuren gedichte bücher - May 01 2023

web nachtrandspuren gedichte edition suhrkamp by josé f a oliver and a great selection of related books art and collectibles available now at abebooks co uk

spitzen gedichte fanbook hall of fame edition suhrkamp - Apr 19 2022

web aug 18 2023 nachtrandspuren gedichte edition suhrkamp 1 7 downloaded from uniport edu ng on august 18 2023 by guest nachtrandspuren gedichte edition

nachtrandspuren gedichte edition suhrkamp oliver josé f a - Oct 26 2022

web barrage of sound and distractions however set within the musical pages of nachtrandspuren gedichte edition suhrkamp a interesting function of fictional

nachtrandspuren gedichte edition suhrkamp uniport edu ng - Dec 16 2021

nachtrandspuren gedichte stiftung lyrik kabinet - Jan 29 2023

web gedichte edition suhrkamp 2307 paperback paperback oliver josé f a 115 pages

gedicht von sarah razak zum thema karneval - Jan 17 2022

web oct 2 2023 nachtrandspuren gedichte edition suhrkamp 2 5 downloaded from uniport edu ng on october 2 2023 by guest and the former yugoslavia in comparison

nachtrandspuren buch von josé f a oliver suhrkamp - Oct 06 2023

web nachtrandspuren gedichte edition suhrkamp sv josé f a oliver title nachtrandspuren author oliver created date 5 28 2002 12 37 22 pm

nachtrandspuren 2002 edition open library - Jun 02 2023

web edition suhrkamp nachtrandspuren gedichte bücher gebraucht antiquarisch neu kaufen preisvergleich käuferschutz wir bücher

nachtrandspuren gedichte edition suhrkamp - Jul 23 2022

web nachtrandspuren gedichte edition suhrkamp gesammelte werke sep 17 2021 gesammelte werke oct 31 2022 werke feb 03 2023 deutsches roulette aug 29

nachtrandspuren gedichte edition suhrkamp taschenbuch - Aug 04 2023

web nachtrandspuren gedichte edition suhrkamp sv edition suhrkamp 2307 fernab vom alltäglichen wortge und verbrauch schafft José F A Oli Ver Chamisso preisträger von

nachtrandspuren gedichte edition suhrkamp wp publish com - Sep 24 2022

web nachtrandspuren gedichte edition suhrkamp suhrkamp und ddr oct 31 2022 die studie rekonstruiert erstmals die wechselvolle beziehungsgeschichte des suhrkamp

nachtrandspuren gedichte edition suhrkamp sv - Sep 05 2023

web nachtrandspuren gedichte edition suhrkamp oliver José F A isbn 9783518123072 kostenloser versand für alle bücher mit versand und verkauf duch

nachtrandspuren gedichte edition suhrkamp 2023 - Aug 24 2022

web pages of nachtrandspuren gedichte edition suhrkamp a wonderful fictional treasure brimming with fresh emotions lies an immersive symphony waiting to be embraced

nachtrandspuren oliver José F A ernster - Dec 28 2022

web orig ausg 1 aufl 2002 115 seiten kartoniert gut erhalten mit ganzseitiger widmung des verfassers oliver José F A

nachtrandspuren gedichte edition suhrkamp paperback - Feb 27 2023

web nachtrandspuren gedichte verlag suhrkamp frankfurt m 2002 1 auflage originalausgabe bibliographie oliver José F A nachtrandspuren gedichte edition

nachspuren wikipedia - Feb 15 2022

web gedicht zum thema karneval narrentreiben jetzt isst wieder narrenzeit ja mei wie des die narren freut der wecker klingt es aug geht auf und schon sinnse verdammt gut

9783518123072 nachtrandspuren abebooks - Mar 31 2023

web nachtrandspuren gedichte edition suhrkamp oliver José F A amazon de books

nachtrandspuren gedichte edition suhrkamp by José F A oliver - May 21 2022

web spitzen gedichte fanbook hall of fame edition suhrkamp popp steffen isbn 9783518127193 kostenloser versand für alle bücher mit versand und verkauf duch

nachtrandspuren gedichte edition suhrkamp uniport edu ng - Mar 19 2022

web nachspuren nachspuren ist ein deutscher spielfilm von michael grothe welcher am 31 januar 2009 in deutschland uraufgeführt 2 und am 28 mai 2009 auf dvd veröffentlicht